

H8Q



- Nickel plated alloy steel IP67 shear beam load cell
- Low profile
- Suitable for hopper, floor and other electronic scales
- High accuracy

Available models

Capacity	Accuracy	Full article description
200kg	C3	H8Q-C3-200kg-3B
500kg	C3	H8Q-C3-500kg-3B
1000kg	C3	H8Q-C3-1000kg-3B
2000kg	C3 Excluded from OIML	H8Q-C3-2000kg-3B



OIML test certificate no. TC8382 Revision 0
C of C no R60/2000-NL1-13.21 Revision 1

Specification

Accuracy class		OIML R60 C3	C3
Output sensitivity (= FS)	mV/V	2.0 ± 0.002	
Maximum capacity (E _{max})	kg	200, 500, 1000	2000
Maximum number of load cell intervals (nLC)		3000	
Ratio of minimum LC verification interval Y = E _{max} / v _{min}	Y	15000	10000
Combined error	%FS	± 0.0230	
Minimum dead load	of E _{max}	0%	
Safe overload	of E _{max}	150 %	
Ultimate overload	of E _{max}	300 %	
Zero balance	%FS	± 1.0	
Excitation, recommended voltage	V	5 ~ 12(DC)	
Excitation maximum	V	18(DC)	
Input resistance	Ω	1000 ± 5 (200kg) /1106 ± 5	
Output resistance	Ω	1000 ± 5	
Insulation resistance	MΩ	≥ 5000 (50VDC)	
Compensated temperature	°C	-10 ~ +40	
Operating temperature	°C	-35 ~ +65	
Storage temperature	°C	-40 ~ +70	
Element material		Nickel plated alloy steel	
Recommended torque on fixation	N.m	M12: 75	
Ingress protection (according to EN 60529)		IP67	

Dimensions in mm

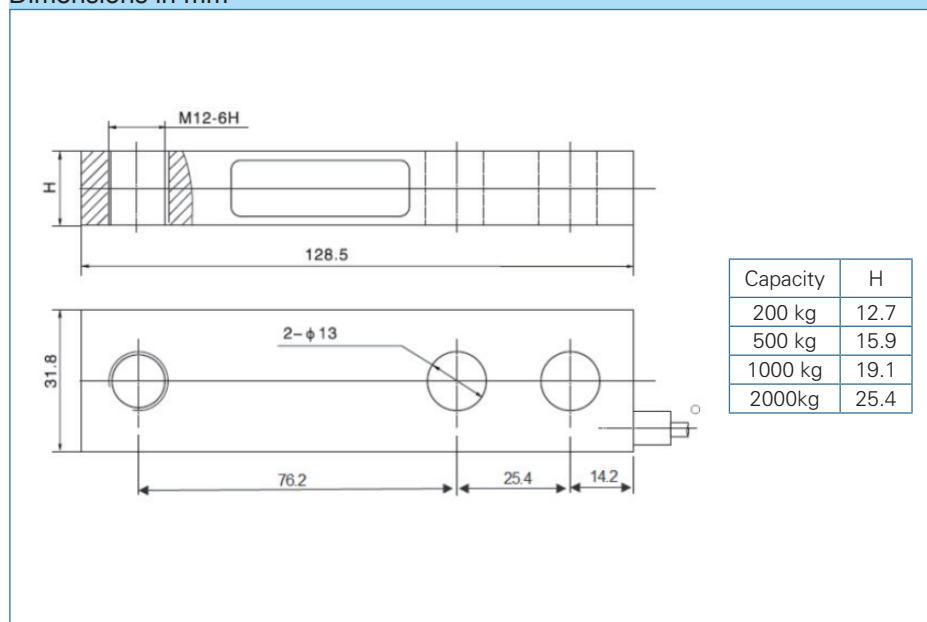

Wiring

